

Industrial Distribution



Justrite Safety Group

Safety Storage
& Material Handling



We support you. Always & Anywhere

We want all of our customers to experience fast and easy access to all of our services and get timely answers and solutions. To do this we take advantage of the Justrite Safety Group proprietary IT tools and systems coupled with the departments organization and management.

Sales support

- Dedicated account managers
- Multi-lingual customer support team
- Field support and joint end user visits
- Support in defining the best custom solution

Worldwide delivery and drop shipment

- Stock of standard products
- Drop shipping optimized packaging
- Custom packing lists and delivery notes
- Fast delivery service

Technical assistance and consultancy

- Remote assistance
- On-site assessment
- On-site consultancy
- Feasibility studies
- Structural analysis and testing
- Data sheets for every product
- Safety Survey STUD-E™

Safety training

Free safety training about safety regulations and the proper use of our products.

After sales and maintenance

Fast answers to your questions, timely service where and when you need it.

Marketing support

All the materials you need are always available for you in various languages.

Our extensive experience in the safety field and our deep knowledge of regulations and standards are at your service to guide you in a complete walkthrough of your facility for clear threat and site vulnerability assessments. We will help you to correct the problems through a printed or emailed document so you can implement it as an action plan for preventing future accidents.

Discover much more on our website sall.it!

Your safety is our priority

Since our foundation in 1975, Sall has experienced rapid growth thanks to continuous investments in technology, innovation and high level skills and competencies.

In 2017 Sall joined Justrite Safety Group, a leading manufacturer in workplace safety and environmental protection founded in 1906, to expand the safety product range.

Sall is a leading Italian brand specialized in designing and manufacturing safety storage and handling solutions.

Sall offers an innovative and complete range of industrial safety equipment for material handling and storage, waste management and spill control.

Our priorities

- EU norms and regulations compliance
- Workplace, people and environmental safety
- Comfort of use, user-friendliness and design to improve efficacy and ease operations

All of our **standard products** and **custom-made solutions** are designed and manufactured in compliance to current regulations and are tested to provide the highest safety level for people, workplace and environment.

The new Sall headquarters is a warehouse dedicated in stock products and a new painting facility for fast delivery and fast colour customization.

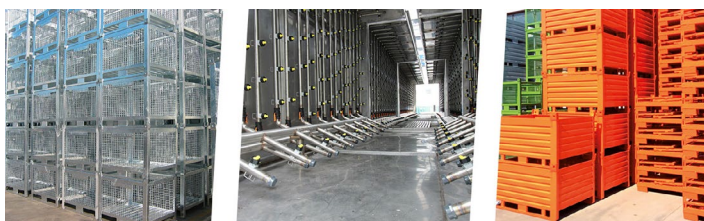

Start with the EssentialSM



A Growing Justrite Family

In recent years we have grown, expanding Justrite Safety Group through the acquisition of other strong, valuable companies. Because of these exciting changes, we want to share our story with you—one of an unrivalled safety portfolio, expertise in environmental protection, a global network of brands, and a steadfast dedication to our customers' safety.

Start with the EssentialSM

The essence of our company is captured in a new tagline: Start with the EssentialSM. At Justrite, everything starts with safety. Protecting people, property and the planet is our first and greatest responsibility. We provide the essential safety products you need to protect your workers and workplace.

Our company logo has recently evolved. The new logo honours our heritage in fire safety, while reflecting our expertise in containment and environmental protection.



Justrite Safety Group offers industrial safety solutions and professional advice from our subsidiaries around the world.

We cover every aspect of industrial safety: from storage, containment and cleaning of hazardous materials, to safety in handling and emergency showers.

Whatever your need, we can help you build the foundation to make your workplace safe and efficient.



Spill pallets



ECO304A

MODEL	DIMENSIONS (L x W x H MM)	STORAGE CAPACITY	CAPACITY (L)
ECO301A	860 x 860 x 430	1 x 200 L drum on grille	206
ECO302A	1340 x 850 x 330	2 x 200 L drums on grille or on europallet 1200 x 800 mm	214
ECO304A	1340 x 1250 x 300	4 x 200 L drums on grille or on europallet 1200 x 1200 mm	271
ECO304HA	1340 x 1250 x 405	4 x 200 L drums on grille or on europallet 1200 x 1200 mm	440

Fast delivery service available for all these products.
 Shipment within 10 working days.
 Please verify the stock with your dedicated sales manager.

Galvanized steel spill pallets - Nestable design



EKON102Z

MODEL	DIMENSIONS (L x W x H MM)	STORAGE CAPACITY	CAPACITY (L)
EKON101Z	800 x 800 x 450	1 x 200 L drum	205
EKON102Z	1200 x 800 x 340	2 x 200 L drums	214
EKON104Z	1200 x 1200 x 300	4 x 200 L drums	270

Fast delivery service available for all these products.
 Shipment within 10 working days.
 Please verify the stock with your dedicated sales manager.

Bunded drum trolleys



ECO310CRA

ECO310CRZ

MODEL	DIMENSIONS (L x W x H MM)	STORAGE CAPACITY	CAPACITY (L)
ECO309CRA	860 x 860 x 1170	1 x 200 L drum directly on grille	206
ECO309CRZ	860 x 860 x 1170	1 x 200 L drum directly on grille	
ECO310CRA	1340 x 850 x 1170	2 x 200 L drums directly on grille or on europallet 1200 x 800 mm	214
ECO310CRZ	1340 x 850 x 1170	2 x 200 L drums directly on grille or on europallet 1200 x 800 mm	

Fast delivery service available for ECO310CRA
 Shipment within 10 working days.
 Please verify the stock with your dedicated sales manager.

Bunded cabinets for outdoor storage



ECO704A

MODEL	DIMENSIONS (L x W x H x INTERIOR H MM)	STORAGE CAPACITY	CAPACITY (L)
ECO701A	870 x 870 x 1600 x 970	1 x 200 L drum directly on grille	206
ECO702A	1350 x 860 x 1570 x 1080	2 x 200 L drums directly on grille or on europallet 1200 x 800 mm	214
ECO704A	1350 x 1260 x 1540 x 1080	4 x 200 L drums directly on grille or on europallet 1200 x 1200 mm	271

Fast delivery service available for ECO702A and ECO704A.
Shipment within 10 working days.
Please verify the stock with your dedicated sales manager.

Bunded cabinets for outdoor storage - Flammable substances



ECO714A

MODEL	DIMENSIONS (L x W x H x INTERIOR H MM)	STORAGE CAPACITY	CAPACITY (L)
ECO712A	1350 x 860 x 1570 x 1080	2 x 200 L. drums directly on grille or on europallet 1200 x 800 mm	214
ECO714A	1350 x 1260 x 1540 x 1080	4 x 200 L drums directly on grille or on pallet 1200 x 1200 mm	271

Bunded cabinets for outdoor storage - Galvanized steel



ECO794Z

MODEL	DIMENSIONS (L x W x H MM)	STORAGE CAPACITY	CAPACITY (L)
ECO792Z	1395 x 905 x 1600	2 x 200 L drums directly on grille or on europallet 1200 x 800 mm	209
ECO794Z	1395 x 1310 x 1660	4 x 200 L drums directly on grille or on pallet 1200 x 1200 mm	400

Stackable spill pallets - 3 side rails



ECO404A

MODEL	DIMENSIONS (L x W x H x INT. H MM)	STORAGE CAPACITY	CAPACITY (L)
ECO402A	1350 x 860 x 1460 x 1070	2 x 200 L drums directly on grille or on europallet 1200 x 800 mm	214
ECO404A	1350 x 1260 x 1430 x 1070	4 x 200 L drums directly on grille or on europallet 1200 x 1200 mm	271



ECO504A

MODEL	DIMENSIONS (L x W x H x INT. H MM)	STORAGE CAPACITY	CAPACITY (L)
ECO502A	1350 x 860 x 1460 x 1070	2 x 200 L drums directly on grille or on europallet 1200 x 800 mm	214
ECO504A	1350 x 1260 x 1430 x 1070	4 x 200 L drums directly on grille or on europallet 1200 x 1200 mm	271



ECO604A

MODEL	DIMENSIONS (L x W x H x INT. H MM)	STORAGE CAPACITY	CAPACITY (L)
ECO602A	1350 x 860 x 1460 x 1070	2 x 200 L drums directly on grille or on europallet 1200 x 800 mm	214
ECO604A	1350 x 1260 x 1430 x 1070	4 x 200 L drums directly on grille or on europallet 1200 x 1200 mm	271

Spill pallets



ECO310A

MODEL	DIMENSIONS (L x W x H MM)	STORAGE CAPACITY	CAPACITY (L)
ECO310A	1340 x 1650 x 620	1 x 1000 L IBC	1000
ECO320A	2720 x 1315 x 420	2 x 1000 L IBC	1000
ECO321A	2720 x 1650 x 350	2 x 1000 L IBC	1000
ECO330A	3280 x 1315 x 420	3 x 1000 L IBC	1200

Fast delivery service available for all these products.
Shipment within 10 working days.
Please verify the stock with your dedicated sales manager.

Spill pallets with top-cover



ECO320TEA

MODEL	DIMENSIONS (L x W x SUMP H x H MM)	STORAGE CAPACITY	CAPACITY (L)
ECO310TEA	2040 x 2000 x 620 x 2265	1 x 1000 L IBC	1000
ECO320TEA	3500 x 1900 x 420 x 2110	2 x 1000 L IBC	1000

Fast delivery service available for all these products.
Shipment within 10 working days.
Please verify the stock with your dedicated sales manager.

Stackable | Spill pallets - 3 side railles



ECO410A

MODEL	DIMENSIONS (L x W x SUMP H x H MM)	STORAGE CAPACITY	CAPACITY (L)
ECO410A	1350 x 1660 x 620 x 1930	1 x 1000 L IBC	1000

Bunded Cabinets for outdoor storage



ECO720A

MODEL	ECO720A
IBC CAPACITY	1
CAPACITY (L)	1000
EXTERNAL DIMENSIONS: L x W x H (MM)	1350 x 1660 x 1900
INT. DIMENSIONS: L x W x H (MM)	1250 x 1615 x 1255
TECHNICAL FEATURES	Equipped with air vents Cover supported by gas shock absorbers
<p>Fast delivery service available for this product. Shipment within 10 working days. Please verify the stock with your dedicated sales manager.</p>	
<p>Can be equipped as optional with an additional polyethylene tank on customer's request.</p>	

Bunded Cabinets for outdoor storage - Galvanized steel



ECO719BZ

MODEL	ECO 719BZ
IBC CAPACITY	1
CAPACITY (L)	1000
EXTERNAL DIMENSIONS: L x W x H (MM)	1405 x 1810 x 2625
DOOR OPENING: L x W x H (MM)	1340 x 1900
INNER WORKING DEPTH (MM)	1650
OPTIONALS	GV719 - Air vents SPC102Z - Tilted support

IBC tilted support - Easy and safe spillage operations

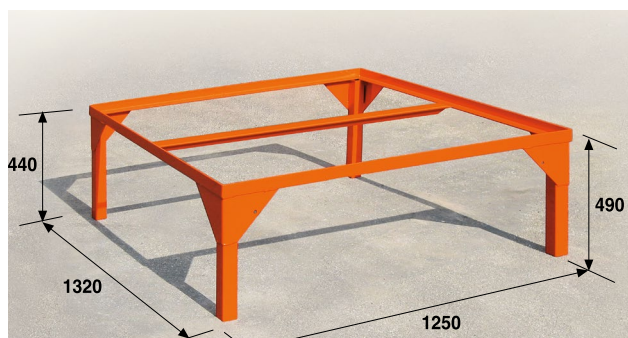

SPC 100

MODEL	DIMENSIONS
	(L x W x MIN. H x MAX. H MM)
SPC100A	1250 x 1320 x 440 x 490
<p>Fast delivery service available for this product. Shipment within 10 working days. Please verify the stock with your dedicated sales manager.</p>	

The SPC100A tilted support has been designed for use with all our spill pallets and facilitates the transfer and dosing operations to ensure that the IBC tank empties completely.

Galvanized supports - Horizontal drums storage

Modular supports - Galvanized steel

MODEL	DESCRIPTION	STORAGE CAPACITY	DIMENSIONS (L x W x H MM)
SPFN451Z	Modular support	1 x 200 L drum	620 x 580 x 411.6
SPFN452Z	Modular support	2 x 200 L drums	1240 x 580 x 411.6
SPFN453Z	Standard support	3 x 60 L drums	1250 x 580 x 409

Stackable at full load 1+1 - Galvanized steel

MODEL	DESCRIPTION	STORAGE CAPACITY	DIMENSIONS (L x W x H MM)
SPFN351Z	Stackable support	1 x 200 L drum	580 x 749 x 810.6
SPFN352Z	Stackable support	2 x 200 L drums	1347 x 580 x 810
SPFN353Z	Stackable support	3 x 60 L drums	1347 x 580 x 810
SPFN048Z	Stackable support	2 x 200 L drums	1300 x 600 x 277

*Supplied with accessory kit to join the 2 supports



SPFN048Z

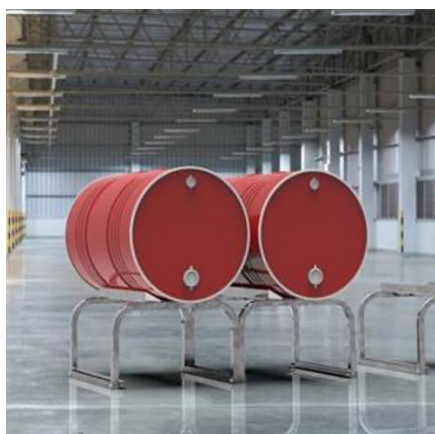

SPFN451Z



SPFN453Z

Standard fixed support



SPFN351Z



SPFN353Z



SPFN048Z

Galvanized supports - Horizontal drums storage

Modular supports in painted steel

MODEL	DESCRIPTION	STORAGE CAPACITY	DIMENSIONS (L x W x H MM)
SPF048A	Stackable support	2 x 200 L	1170 x 750 x 360
SPF351A	Stackable support	1 x 200 L	835 x 600 x 810
SPF352A	Stackable support	2 x 200 L	1335 x 600 x 810
SPF353A	Stackable support	3 x 60 L	1335 x 600 x 810
SPF451A	Standard support	1 x 200 L	600 x 600 x 380
SPF452A	Standard support	2 x 200 L	1180 x 600 x 380
SPF453A	Standard support	3 x 60 L	1180 x 600 x 380

Available on customer's request in galvanized steel.



SPF048A



SPF452A

Multipurpose container



SPF452A

MODEL	DIMENSIONS				CAPACITY (KG)
	L x W x H CLOSED x H OPEN (MM)				
SR163A	1000	1000	1160	2110	400

Fast delivery service available for t his products.
 Shipment within 10 working days.
 Please verify the stock with your dedicated sales manager.

The Sall multipurpose painted steel container can be used for extraordinary aerial maintenance with due diligence.

The main basket can be used when no other safety platform or equipment is able to provide a superior safety level. The multipurpose painted steel containers are for urgent repairs and can be safely used with a forklift thanks to the forklift sleeves which are equipped with a safety mechanism to prevent slipping.

Available also with wheels: 2 fixed and 2 castors with brakes. This multipurpose container comes with a user manual, warning signs, and an identification plate.

Bunded chemical storage buildings - Modular design



MCOK12PSZ

MODEL	MCOK12PSZ
EXTERNAL DIMENSIONS: L x W x H (MM)	7230 x 1710 x 3480
NET LIGHT DOOR OPENING (MM)	3450 x 2750
INT. WIDTH (MM)	1340
COLLECTION VOLUME (L)	4000
IBC CAPACITY	12
OPTIONALS	TSK12 - Insulated roof GV343 - Air vents



MCOKB4PSZ

MODEL	MCOKB4PSZ
EXTERNAL DIMENSIONS: L x W x H (MM)	5470 x 1710 x 2600
NET LIGHT DOOR OPENING (MM)	2600 x 2080
INT. WIDTH (MM)	1360
COLLECTION VOLUME (L)	1900
IBC CAPACITY	4
OPTIONALS	TSKB4 - Insulated roof GV343 - Air vents



MCO925Z

MODEL	MCO925Z
EXTERNAL DIMENSIONS: L x W x H (MM)	5150 x 2350 x 2365
INT. DIMENSIONS: L x W x H (MM)	4940 x 2140 x 2000
COLLECTION VOLUME (L)	1700

Bunded chemical storage buildings - Modular design



MCO925IT

MODEL	MCO925IT
EXTERNAL DIMENSIONS: L x W x H (MM)	5150 x 2350 x 2350
INT. DIMENSIONS: L x W x H (MM)	4880 x 2080 x 2000
COLLECTION VOLUME (L)	1700
TECHNICAL FEATURE	Insulated
Please verify the stock with your dedicated sales manager.	

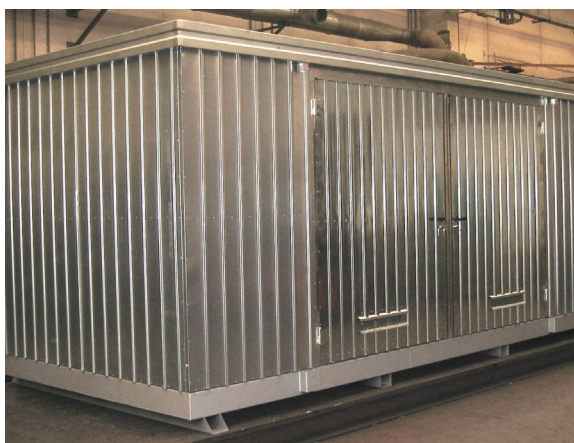

MCO952Z

MODEL	MCO952Z
EXTERNAL DIMENSIONS: L x W x H (MM)	5150 x 2350 x 2365
INT. DIMENSIONS: L x W x H (MM)	4940 x 2140 x 2000
COLLECTION VOLUME (L)	1700
Please verify the stock with your dedicated sales manager.	



MCO952IT

MODEL	MCO925IT
EXTERNAL DIMENSIONS: L x W x H (MM)	5150 x 2350 x 2350
INT. DIMENSIONS: L x W x H (MM)	4940 x 2140 x 2000
COLLECTION VOLUME (L)	1700
TECHNICAL FEATURE	Insulated
Please verify the stock with your dedicated sales manager.	

Bunded chemical storage buildings - Modular design



MCO 923 Z

RAMCO

MODEL	MCO923Z/ZB	MCO923ADZ/ADZB	Ramco/280Z
EXTERNAL DIMENSIONS: L x W x H (MM)	3150 x 2350 x 2365	3325 x 2350 x 2365	960 x 1000 x 280
INT. DIMENSIONS: L x W x H (MM)	2940 x 2140 x 2000	2940 x 2140 x 2000	-
COLLECTION VOLUME (L)	1000	1000	-



MCO923IT

MODEL	MCO923IT
EXTERNAL DIMENSIONS: L x W x H (MM)	3150 x 2350 x 2350
INT. DIMENSIONS: L x W x H (MM)	2880 x 2080 x 2000
COLLECTION VOLUME (L)	1000
TECHNICAL FEATURE	Insulated



MCO912Z

MODEL	MCO912Z
EXTERNAL DIMENSIONS: L x W x H (MM)	2350 x 1150 x 2365
INT. DIMENSIONS: L x W x H (MM)	2140 x 940 x 2000
COLLECTION VOLUME (L)	300



ECO732NZ

MODEL	ECO732NZ
IBC capacity	2
EXTERNAL DIMENSIONS: L x W x H (MM)	3000 x 1870 x 2390
Door opening: L x W x H (MM)	2685 x 1885
INNER WORKING WIDTH (MM)	1655
OPTIONAL	GV 732 - Air vents TS732 - Insulating top

Storage deposits for gas cylinders



PBO015SBZ

MODEL	EXTERNAL DIMENSIONS L x W x H (MM)	CYLINDER CAPACITY
PBO015SBZ without base	1550 x 1210 x 2285	1 pallet + 4 cylinders or 2 compartments each for 3 rows of 4 cylinders
PBO015CBZ with base	1550 x 1210 x 2450	1 pallet + 4 cylinders or 2 compartments each for 3 rows of 4 cylinders
Accessories (optional)	Ramp PBO015Z	

Fast delivery service available for PBO015CBZ WITH BASE.
Shipment within 10 working days.
Please verify the stock with your dedicated sales manager.



BENEFITS OF FLAT PACK VERSION:

- Easy assembling
- Reduced freight cost
- Suitable for limited access areas
- Easy handling operations

Storage deposits for gas cylinders



PBO011CBZ

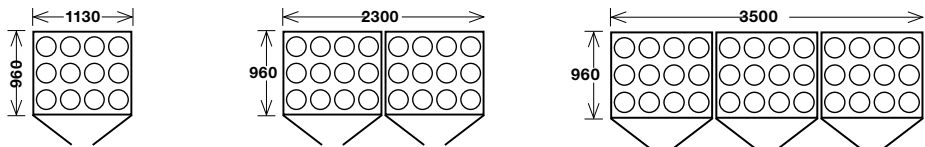

MODEL	PBO011CBZ	PBO023CBZ	PBO035CBZ
NUMBER OF CYLINDERS	9/12	18/24	27/36
DIMENSIONS L x W x H (MM)	1130 x 960 x 2100	2300 x 960 x 2100	3500 x 960 x 2100
ACCESSORIES (OPTIONAL)	PBO011/1R SHELF CAN BE EASILY ADDED AND REMOVED TO EACH MODEL		

Fast delivery service available for PBO011CBZ.
Shipment within 10 working days.
Please verify the stock with your dedicated sales manager.



PBO030SBZ

MODEL	PBO030CBZ	PBO030SBZ
NUMBER OF CYLINDERS	2 PALLETS + 8 CYLINDERS OR 4 COMPARTMENTS EACH FOR 3 ROWS OF 4 CYLINDERS.	2 PALLETS + 8 CYLINDERS OR 4 COMPARTMENTS EACH FOR 3 ROWS OF 4 CYLINDERS.
DIMENSIONS L x W x H (MM)	3180 x 1600 x 2450	3180 x 1600 x 2285
DIFFERENCE AMONG THE TWO MODELS	WITH BASE	WITHOUT BASE

Forkliftable pallet cages for gas cylinders



MODEL	NUMBER OF CYLINDERS Ø 230 MM	EXTERNAL DIMENSIONS L x W x H (MM)
PBO 04Z	4	860 x 650 x 1115
PBO 08Z	8	860 x 1170 x 1115
PBO 12Z	12	1030 x 805 x 1225

Fast delivery service available for PBO012Z.
Shipment within 10 working days.
Please verify the stock with your dedicated sales manager.

PBO08Z

BIG BAGS HANDLING

Big bag holder racks - Stackable design



MODEL	SURFACE TREATMENT	DIMENSIONS L x W x H (MM)	CAPACITY (KG)	CAPACITY (L)
SPB120Z	GALVANIZED	1070 x 1070 x 1350	1000	-
SPB122A	ORANGE	1000 x 1000 x 1860	1000	208
SPB122Z	GALVANIZED	1000 x 1000 x 1860	1000	208
SPB122CRA	ORANGE	1000 x 1000 x 1998	900	208
SPB122CRZ	GALVANIZED	1000 x 1000 x 1998	900	208

Fast delivery service available for SPB120Z.
Shipment within 10 working days.
Please verify the stock with your dedicated sales manager.

SPB120Z



SPB 122Z



SPB 122CRA

STACKABLE BIG BAG PALLET

- Mesh bottom with removable uprights
- Hot-galvanised carbon steel construction
- Suitable for holding 1000-litre Big Bags (or flexible bag).

On request, as an optional, 1000-litre Big Bag is available

BIG BAG HOLDER PALLET

- Featuring a watertight safety tray for liquids with removable galvanised grid.
- Four pull-out uprights.
- Upper Big Bag holder frame that snaps into the four pull-out uprights.

Tipping skips containers

- Simple and safe automatic emptying.
- Equipped with watertight bin, they can be easily moved by hand into the work position thanks to four large diameter.
- Wheels (two fixed and two swivel) mounted on bearings.
- All the models are available in orange, green, blue.



LT300A

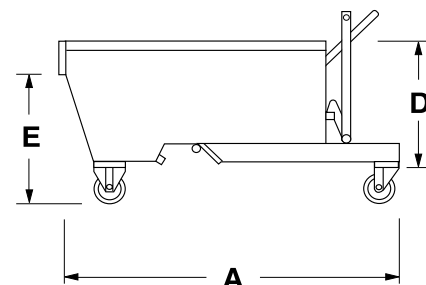
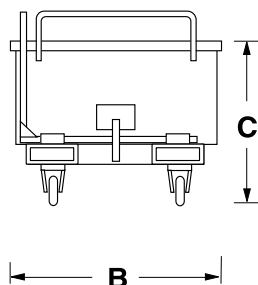

LT300V

MODEL	DIMENSIONS (MM)					CAPACITY (KG)	VOLUME (L)
	A	B	C	D	E		
LT300A	1350	820	650	490	520	600	285
LT300B	1350	820	650	490	520	600	285
LT300V	1350	820	650	490	520	600	285

Fast delivery service available for all these products.
Shipment within 10 working days. Please verify the stock with your dedicated sales manager.



LT300B

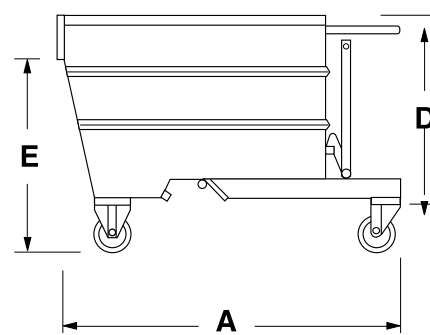
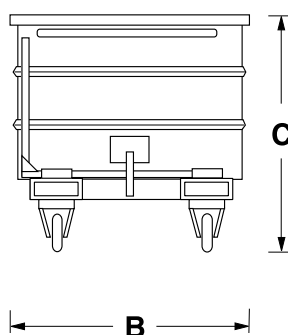

LT750V

MODEL	DIMENSIONS (MM)					CAPACITY (KG)	VOLUME (L)
	A	B	C	D	E		
LT500A	1350	920	910	700	740	1000	490
LT500B	1350	920	910	700	740	1000	490
LT500V	1350	920	910	700	740	1000	490
LT750A	1350	1070	1040	825	800	1350	755
LT750B	1350	1070	1040	825	800	1350	755
LT750V	1350	1070	1040	825	800	1350	755

Fast delivery service available for all these products.
Shipment within 10 working days. Please verify the stock with your dedicated sales manager.

Tipping skips containers



LT1000A

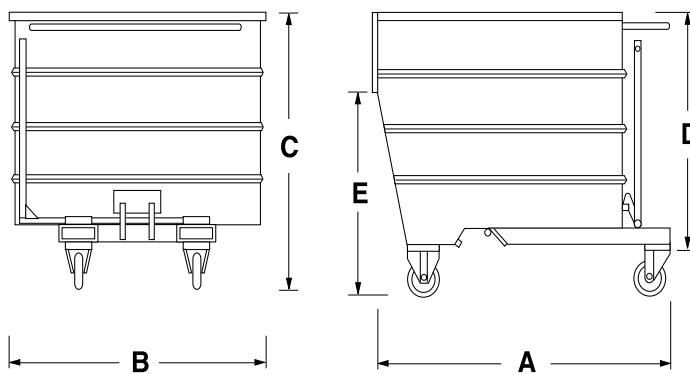

LT1000V



LT1000B

MODEL	DIMENSIONS (MM)					CAPACITY (KG)	VOLUME (L)
	A	B	C	D	E		
LT1000A	1550	1070	1210	970	920	1700	1070
LT1000B	1550	1070	1210	970	920	1700	1070
LT1000V	1550	1070	1210	970	920	1700	1070
LT1350A	1550	1320	1210	970	920	2000	1320
LT1350B	1550	1320	1210	970	920	2000	1320
LT1350V	1550	1320	1210	970	920	2000	1320
LT1600A	1550	1550	1210	970	920	2000	1610
LT1600B	1550	1550	1210	970	920	2000	1610
LT1600V	1550	1550	1210	970	920	2000	1610
LT2000A	1550	1950	1210	970	920	2000	2040
LT2000B	1550	1950	1210	970	920	2000	2040
LT2000V	1550	1950	1210	970	920	2000	2040

Fast delivery service available for all these products. Shipment within 10 working days. Please verify the stock with your dedicated sales manager.

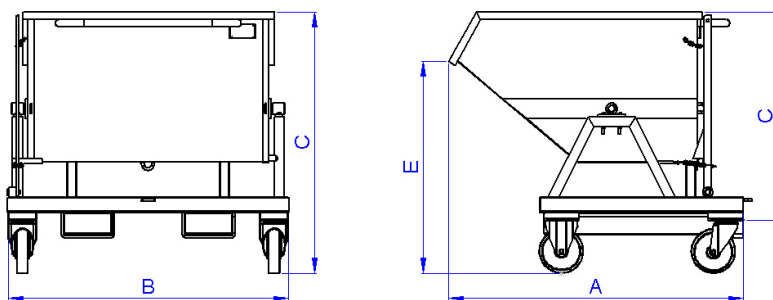

LT470V

MODEL	DIMENSIONS (MM)					CAPACITY (KG)	VOLUME (L)
	A	B	C	D	E		
LT0450A	1190	1070	935	210	620	1000	400
LT0450B	1190	1070	935	210	620	1000	400
LT0450V	1190	1070	935	210	620	1000	400
LT0460A	1175	1120	830	210	680	1000	438
LT0460B	1175	1120	830	210	680	1000	438
LT0460V	1175	1120	830	210	680	1000	438
LT0470A	1205	1260	1075	210	815	1000	675
LT0470B	1205	1260	1075	210	815	1000	675
LT0470V	1205	1260	1075	210	815	1000	675

Accessories for tipping skips containers

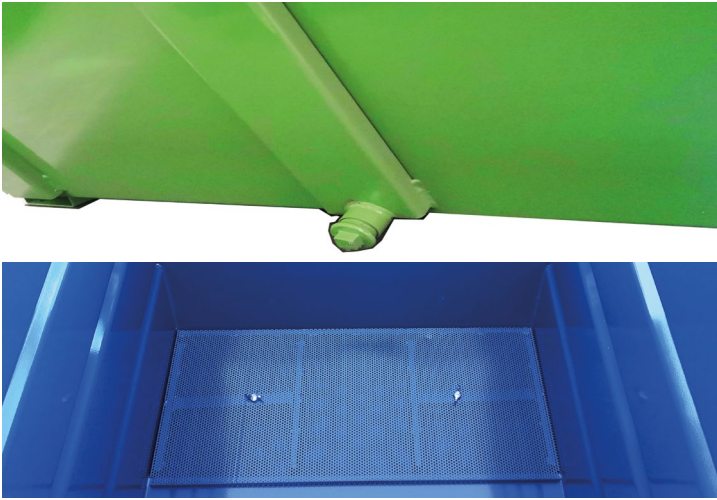

MODEL	AVAILABLE ALSO FOR THE MODELS:
VR0300	LT300
VR0450	LT450
VR0460	LT0460
VR0470	LT0470
VR0500	LT500
VR0750	LT750
VR1000	LT1000
VR1350	LT1350
VR1600	LT1600
VR2000	LT2000

Setting tank equipped with grid and ball valve ideal to separate liquid from solid substances.

Tipping skip dump bucket



MODEL	DIMENSION (MM)			CAPACITY KG
	A	B	C	
SL164R	1420	1270	570	1000

MAIN FEATURES

- Suitable for loose goods
- Steel structure
- Anti-slip safety chain
- Safety device to prevent accidental dumping

Roll Forward Polyethylene tipping skips



MODEL	DIMENSIONS			CAPACITY (KG)	CAPACITY (L)
	L x W x H (MM)				
POLYRIB1000	1420	1270	570	1000	1000

FAST DELIVERY SERVICE AVAILABLE FOR THIS PRODUCT.
SHIPMENT WITHIN 10 WORKING DAYS.
PLEASE VERIFY THE STOCK WITH YOUR DEDICATED SALES MANAGER.

Sturdy structure made of ecologic high-density polyethylene. The best solution for the safe transport and unloading of all the industrial materials, waste, or scrap.

Drop bottom opening skips containers - 1 bottom



MODEL	DIMENSIONS (MM)					CAPACITY (Kg)
	A	B	C	D	E	
SL154AA	1000	800	650	100	110	1300
SL154AB	1000	800	650	100	110	1300
SL154AG	1000	800	650	100	110	1300
SL154BA	1200	1000	650	100	110	1400
SL154BB	1200	1000	650	100	110	1400
SL154BG	1200	1000	650	100	110	1400
SL154CA	1500	1000	1000	100	110	1400
SL154CB	1500	1000	1000	100	110	1400
SL154CG	1500	1000	1000	100	110	1400

- Simple and safe automatic emptying.
- Mechanism to prevent automatic openings

Drop bottom opening skips containers - 2 bottoms



MODEL	DIMENSIONS (MM)					CAPACITY (Kg)
	A	B	C	D	E	
SL064H650A	1000	800	650	110	110	2000
SL064H650G	1000	800	650	110	110	2000
SL064H650B	1000	800	650	110	110	2000
SL064H1000A	1000	800	1000	110	110	2000
SL064H1000G	1000	800	1000	110	110	2000
SL064H1000B	1000	800	1000	110	110	2000
SL064H1300A	1000	800	1300	110	110	2000
SL064H1300G	1000	800	1300	110	110	2000
SL064H1300B	1000	800	1300	110	110	2000



MODEL	DIMENSIONS					CAPACITY (Kg)
	A	B	C	D	E	
SL153AA	1500	1000	650	110	110	2000
SL153AG	1500	1000	650	110	110	2000
SL153AB	1500	1000	650	110	110	2000
SL153BA	2000	1000	1000	110	110	2000
SL153BG	2000	1000	1000	110	110	2000
SL153BB	2000	1000	1000	110	110	2000



Sall, the Italian highly specialized manufacturer in chemicals material handling and storage since 1975. The core business includes an innovative product range, for environmental, people and workplace safety.

In 2017 Sall joined the Justrite Safety Group, the leading multinational company in the industrial safety sector.

Secondary Spill Containment:

- Spill pallets
- Storage Cabinets
- Drum Trolleys
- Absorbent Spill Kits
- Bunded Flooring Systems

Materials Storage:

- Modular Storage Buildings
- Storage Buildings
- Gas Cylinders Deposits
- Safety Cabinets
- Metal Containers
- Waste Containers

Materials Handling:

- Tipping Skips Containers
- Drop Opening Bottoms Containers
- Dump Buckets
- Pallet & Stillages
- Bigbags Holder Racks

Accessories for material handling and storage as well as for workplace safety.

Discover why Sall is your key partner for chemicals safe storage and handling and much more on our website:
sall.it

